

Diese Zeichnung ist unser geistiges Eigentum und darf ohne unsere Ermächtigung weder kopiert, vervielfältigt noch Dritten oder Konkurrenzfirmen zugänglich gemacht werden. (Art. 12 B.G.)
 This drawing is copyright. Information contained thereon is supplied in confidence and must not be used for any other purpose than which it was supplied, or be reproduced without written permission of the owners.

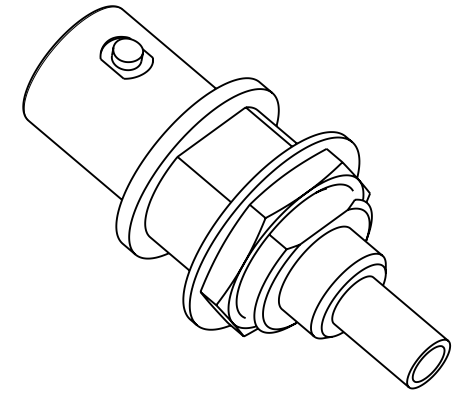

Mounting hole
ML 3

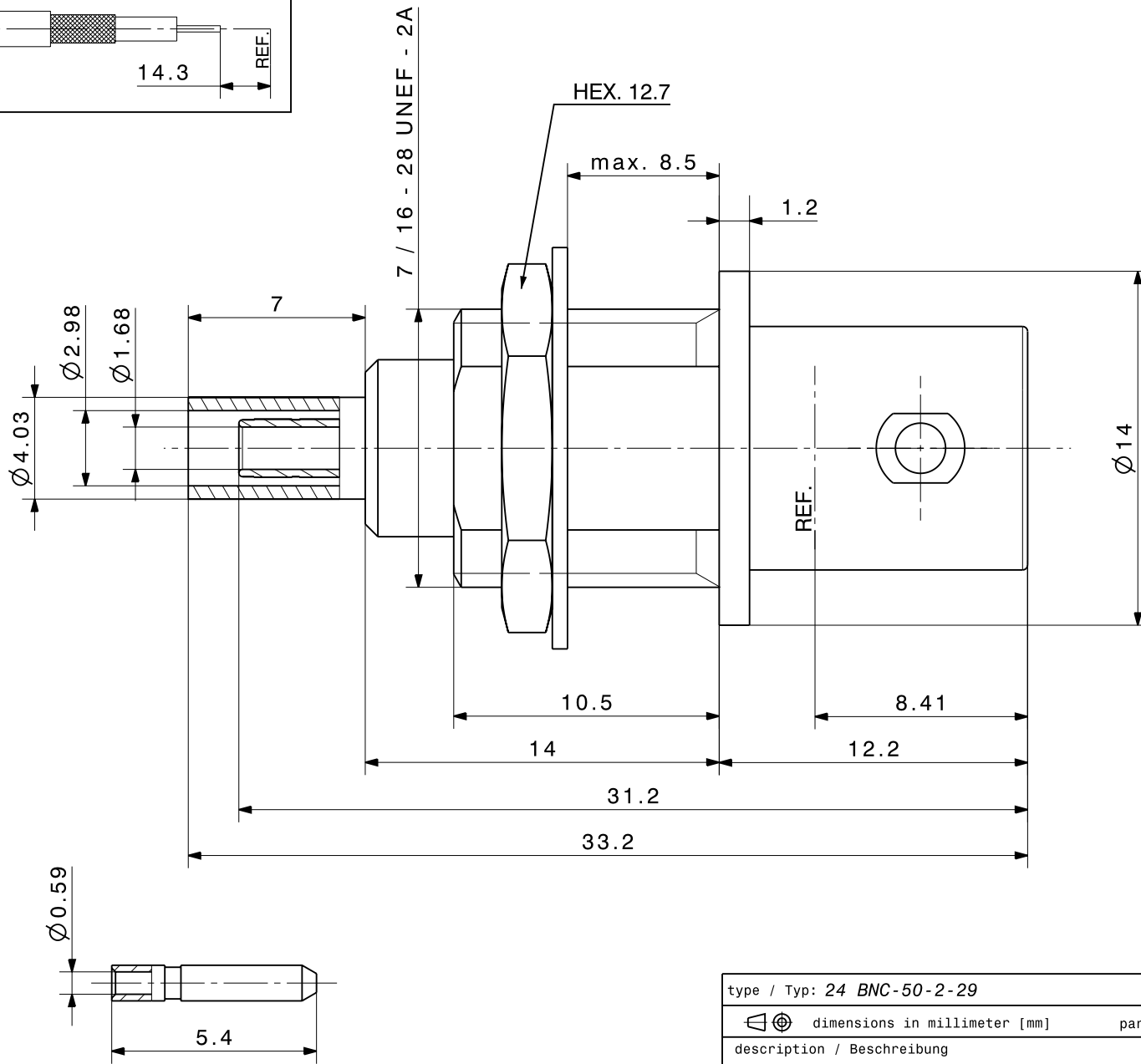
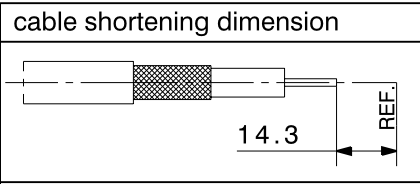
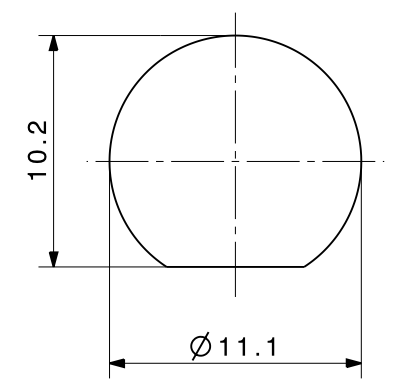

type / Typ: 24 BNC-50-2-29		
dimensions in millimeter [mm]	part no. / Teile Nr.: PRO-00015150	A sheet/Blatt XX / XX
description / Beschreibung	drawing-no. / Zeichnungsnr.	Release
Bulkhead cable jack	DOU-00015150	C

Diese Zeichnung ist unser geistiges Eigentum und darf ohne unsere ausdrückliche Einwilligung weder kopiert, vervielfältigt, noch Dritten oder Konkurrenzfirmen zugänglich gemacht werden. (Art. 12 B.G.)

This drawing is copyright. Information contained thereon is supplied in confidence and must not be used for any other purpose than which it was supplied, or be reproduced without written permission of the owners.

24 BNC 50 - 2 - 29 ML 3

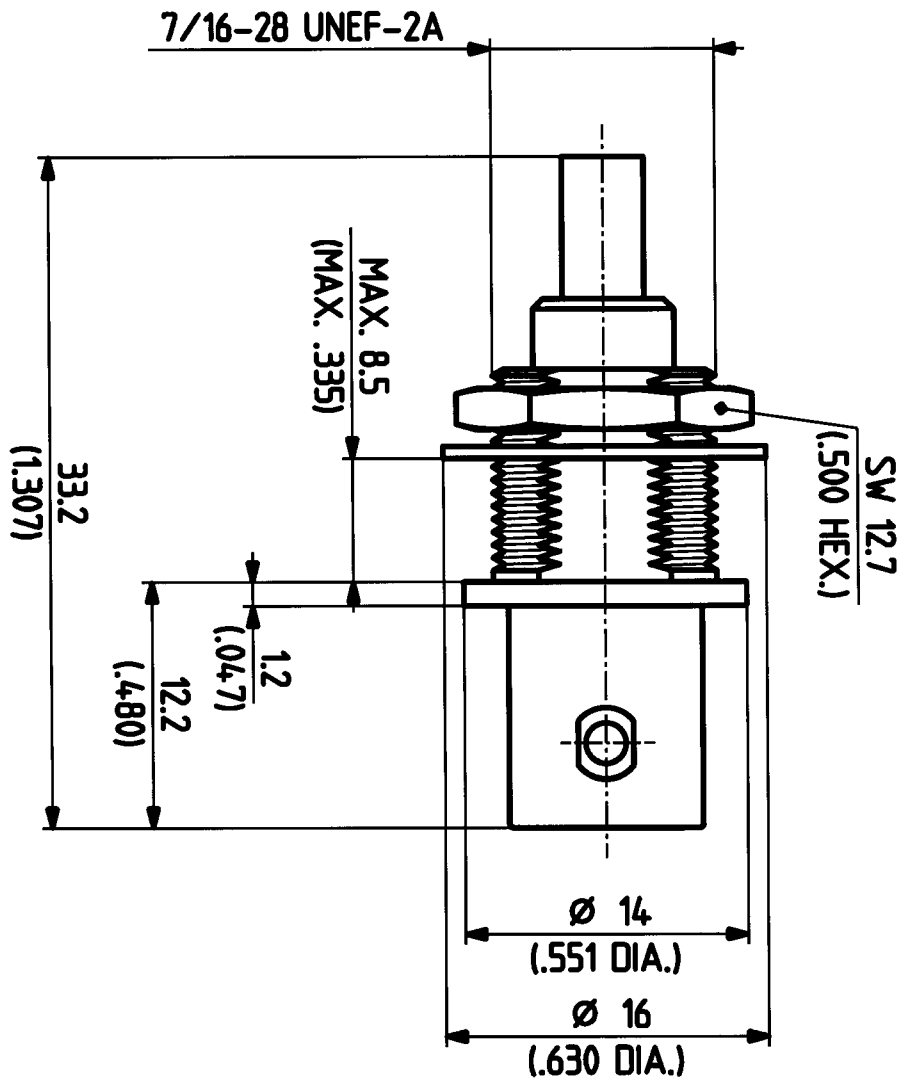

M. 4:1



HUBER + SUHNER AG
9100 Herisau

3.13.03904_1

a

Erstellt	21.02.96	Datum	023/TUB	Kurz-/Vorn
Geprüft	22.2.96	Freigebe	22.2.96	FR/AL/RS

This drawing is copyright. Information contained thereon is supplied in confidence and must not be used for any other purpose than which it was supplied, or be reproduced without written permission of the owners.

Montageloch ML 3
 Mounting hole ML 3

	Datum	Kurzz./Visum
Erstellt	24.08.95	726/SMA/S
Geprüft	10.11.95	726 / Bam
Freigabe	10.11.95	726 / Bam

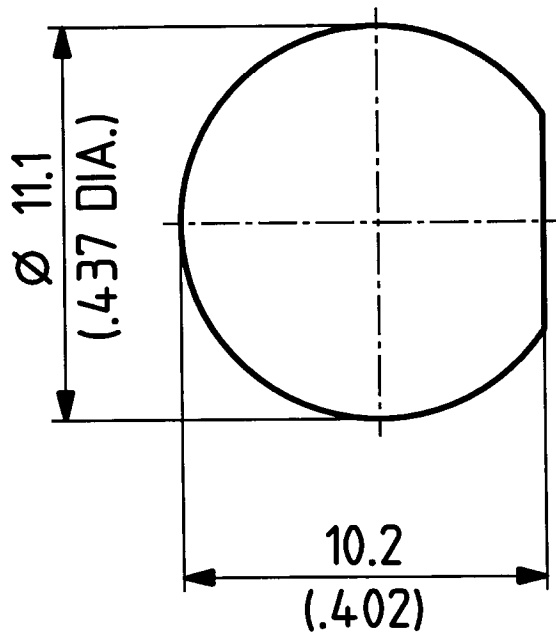

Diese Zeichnung ist unser geistiges Eigentum und darf ohne unsere ausdrückliche Einwilligung weder kopiert, vervielfältigt, noch Dritten oder Konkurrenzfirmen zugänglich gemacht werden. (Art. 12 B.G.)

M. 5 : 1



HUBER + SUHNER AG
 9100 Herisau

4.13.24027_1

a

Assembly instruction Series BNC B No. 9068

Tools and materials required:

Stanley blade
Scissors
Crimp tool (see table below)

Straight connectors for flexible cable

Cable entry: SUHNER Full-Crimp

Connector types: (e. g.)

11 BNC-50-1-5c	11 BNC-50-2-13c	11 BNC-50-2-16c
21 BNC-50-1-4c	21 BNC-50-2-9c	
	24 BNC-50-2-13c	

This connector is supplied in 3 parts

Suitable cables e. g.:

Centre contact:

Braid:

Crimp tool:

RG 196 A/U

cavity 1

cavity A

1, 2, A (red)

RG 188 A/U

cavity 1

cavity A

1, 2, A (red)

G 01130 HT *1

cavity 1

cavity A

1, 2, A (red)

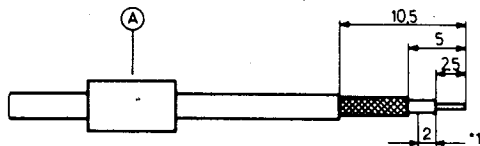
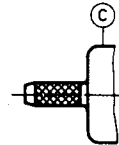
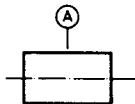

Slide ferrule A onto cable.

Prepare cable according to diagram.

CAUTION: Do not damage braid, dielectric and inner conductor of cable.

*1 Remove semi conducting layer 2 mm towards braid.

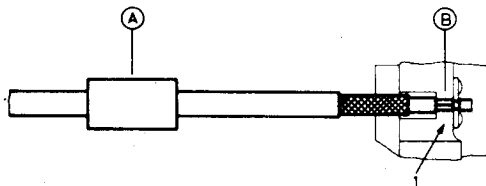

Push contact B over inner conductor of cable to abut cable dielectric and crimp with insert 1.

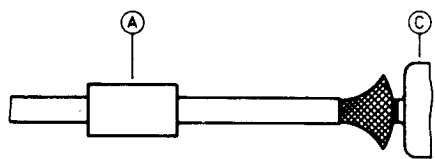

Splay out braid and insert cable in connector body C. Ensure that braid lies above the crimp neck.

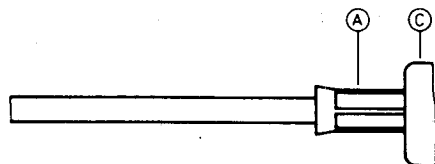

Slide ferrule A over braid

and crimp as close to connector body C as possible.



SUHNER's skilled staff and specialised equipment are available to carry out complete R. F. lead-assembly on your behalf. We mount your connectors on cables at economic prices! Please contact our representative for further details of this service.



HUBER+SUHNER LTD. CH-9100 HERISAU

Deutscher Text: siehe Rückseite